

STUDENT'S WORKSHEETS

FOUNDATION PROGRAMME FOR LITERACY
NUMERACY AND SKILLS

INSTRUMENTAL MUSIC

GRADE 7

**TITLE :: FESTIVALS AND
MUSICAL INSTRUMENTS OF MAURITIUS**

**MOE
MAHATMA GANDHI INSTITUTE
2026**

TABLE OF CONTENTS

Student's Worksheet	01
Introduction	02
Part 1	02
Part 2	03
Part 3	04
Worksheet	05-06
Progress	07

GRADE 7

STUDENT'S WORKSHEET

TITLE : FESTIVALS AND MUSICAL INSTRUMENTS IN MAURITIUS



INTRODUCTION

In this lesson, you will learn about the different festivals celebrated in Mauritius and the music connected to them. Mauritius is a multicultural country, and each community has its own special celebrations and musical traditions.

You will explore how music is used during religious, cultural, and community festivals. In groups, you will discuss, research, and prepare a short presentation about a festival. You will also identify the musical instruments used and, if possible, perform a simple rhythm related to the celebration.

Through this activity, you will learn to respect different traditions, appreciate our cultural diversity, and work together as a team while enjoying music and performance.

Part 1

Festivals and Musical Instruments of Mauritius

- Listen carefully as your teacher explains on the importance of music in the Mauritian cultural life.

You are expected to discuss on the following:

- What festivals are celebrated in Mauritius?
- How is music used during festivals?
- Observe and listen carefully as your teacher shows pictures or videos of key musical instruments used in Mauritian festivals.

Part 2

(GROUP ACTIVITY) - Cultural Fair Simulation

- Your teacher will place you in small groups
- Each group will be assigned one festival celebrated in Mauritius.
- Each group should:
 - Prepare a mini presentation on their festival.
 - Identify musical instruments or music related to the celebration.

Some examples of musical instruments are given below

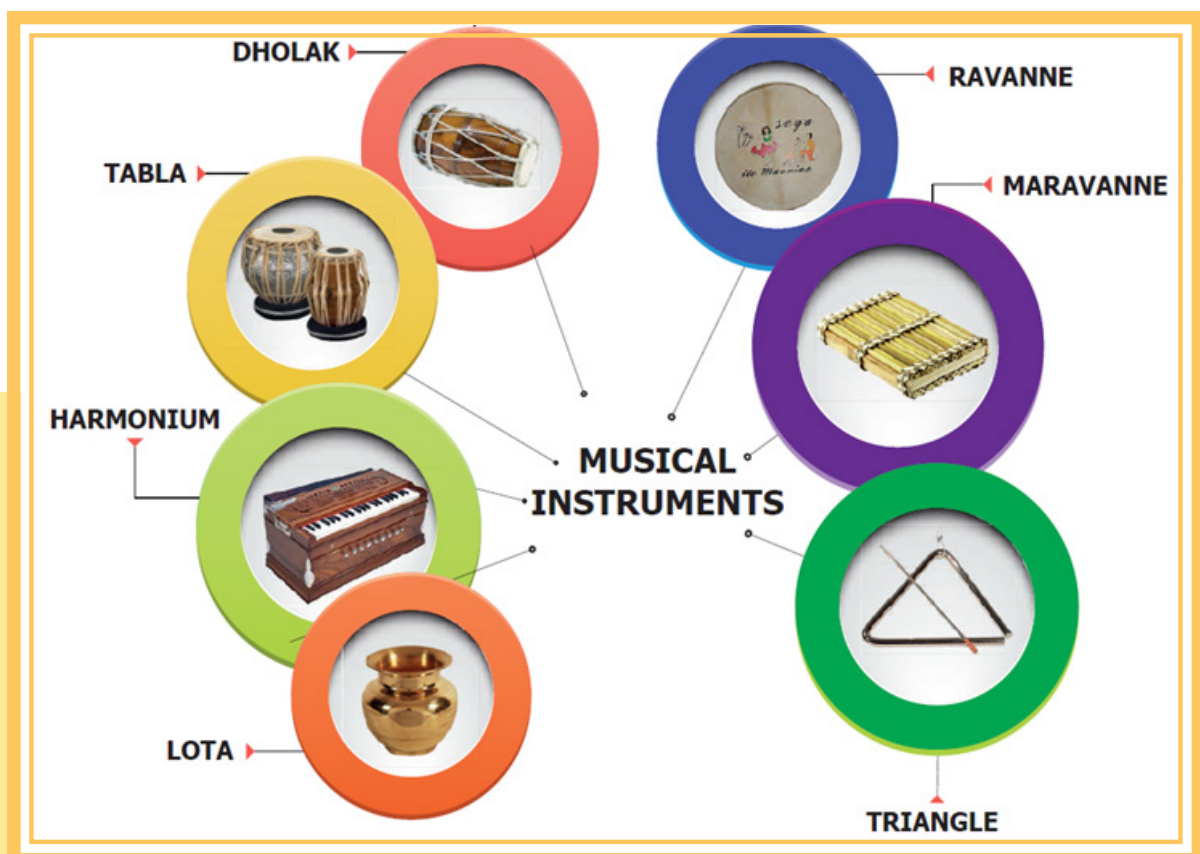

- You will listen to clips of music being played during those festivals.
- You will be provided with basic percussion instruments (or improvised ones like shakers) with which you will be playing simple rhythmic patterns to accompany music played in a chosen festival.

Part 3

Sharing & Reflection

- Your group will present the festival and musical findings assigned to the group by your teacher.
- Finally, you will take part in a fun group performance. Follow your teacher and play or clap along to a simple Sega rhythm led by the Ravanne or with an audio track.

WORKSHEET

Instructions:

- Join the dots following the numbers in consecutive order to complete the pictures of the following musical instruments and then color them.
- Carefully cut out each instrument along the dotted lines.
- Paste each instrument into the correct festival box on the next page.

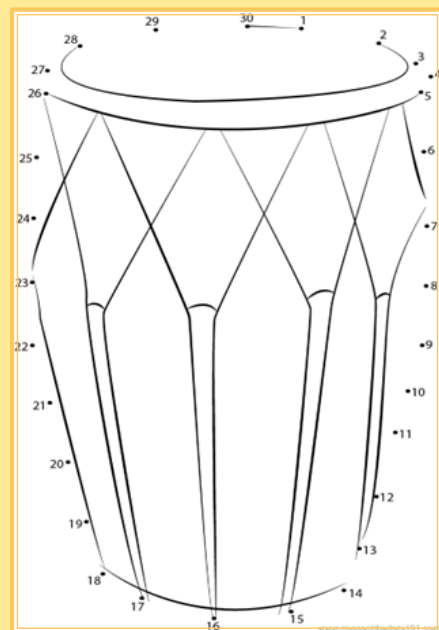
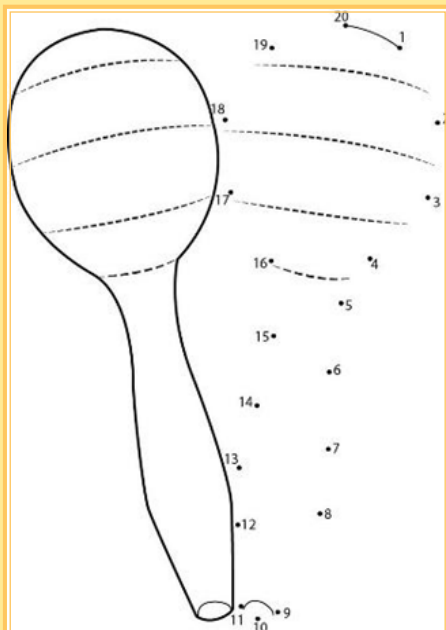
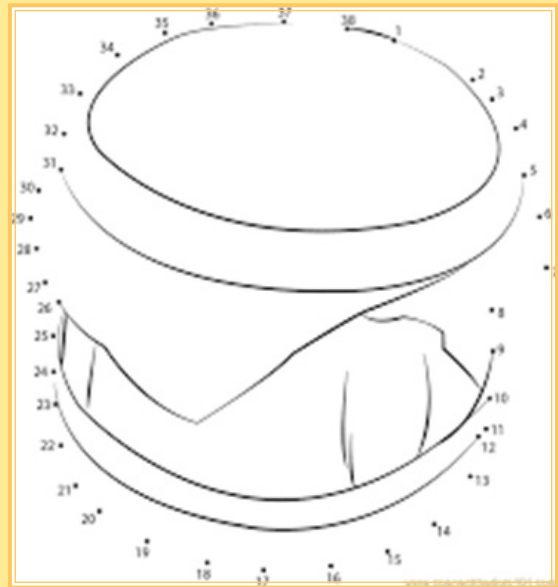
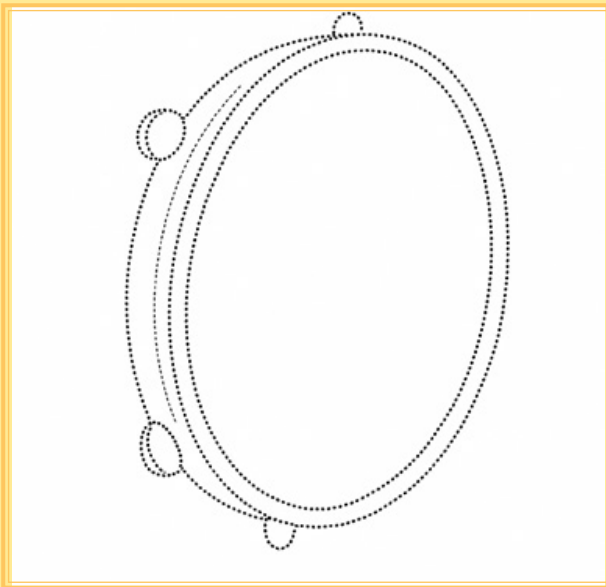



**Festivals in
Mauritius**



Easter

Holi

Chinese Spring Festival

PROFILING: (Tick Appropriately)

Lesson 6 - Festivals ; MY PROGRESS?

			
	Good	Satisfactory	Needs Improvement
What have I Learnt?			
1. Importance of music Mauritian cultural life			
2. What festivals are celebrated in Mauritius?			
3. How is music used during festivals?			
4. Associating musical instruments with festivals			
5. Group presentation			



**MOE
MAHATMA GANDHI INSTITUTE
2026**

